

Thermal Circuit Breaker, rotary knob actuation, 1-, 2- or 3-pole

NEW



2-pole standard version



3-pole type without front bezel/knob



standard front bezel/knob



Description

- Thermal circuit breaker 1-, 2- or 3-pole
- Supplementary protector for general industrial use
- Positively trip-free release
- Bezel/knob snap-on
- Easy actuation with gloves
- Front elements can be done by customer

Standards

- IEC 60934
- UL 1077
- CSA C22.2 235
- GB 17701

Applications

- High pressure cleaners
- Floor cleaning equipment
- Power tools
- Wood and stone working machines
- Equipment for building construction
- Industrial equipment
- Commercial kitchen appliances

Weblinks

Approvals: <http://www.schurter.com/approvals>
 RoHS: <http://www.schurter.com/rohs>

Technical Data

Rated voltage U_e	1-pole	AC 240 V / 50/60 Hz DC 32 V
	2-pole	AC 240 V / 50/60 Hz DC 60 V
	3-pole	AC 415 Y/240 V / 50/60 Hz
Rated current I_n	1- / 2-pole	0.05 – 20 A
	3-pole	0.05 – 12 A
Conditional short circuit I_{nc}	1- / 2-pole, AC 240 V	0.05...20 A: 2000 A, SC (C1)
	3-pole, AC 415 V	0.05...12 A: 2000 A
Degree of protection	Accessible range	IP 40
	Terminal side	IP 00
Dielectric strength	50 Hz	> 2500 V
	Impulse 1.2/50 μ s	> 4000 V
Insulation resistance	DC 500 V	> 100 M Ω m
Endurance (typical)	Mechanical	50'000 cycles
	AC: 1 x I_n , cos phi 0.6	50'000 cycles
	DC: 1 x I_n , L/R = 2...3ms	50'000 cycles

Overload	IEC 60934	min. 40 cycles @ 6 x I_n , cos phi 0.6
	UL 1077	min. 50 cycles @ 1.5 x I_n , cos phi 0.75 (OL \emptyset)
Admissible ambient air temperature		-30 °C to +60 °C
Resistance to vibration	IEC 60068-2-6, Test Tc	10...60 Hz: \pm 0.75 mm
		60...500 Hz: 10 G
Shock resistance	IEC 60068-2-27, Test Ea	30 G / 18 ms
Type of tripping		Thermal positively trip free
Weight	1-pole	45 g
	2-pole	60 g
	3-pole	75 g
Max. switching capacity for switch only types (without bimetal)	1-, 2-pole	20 A
	3-pole	12 A

Tripping Characteristics

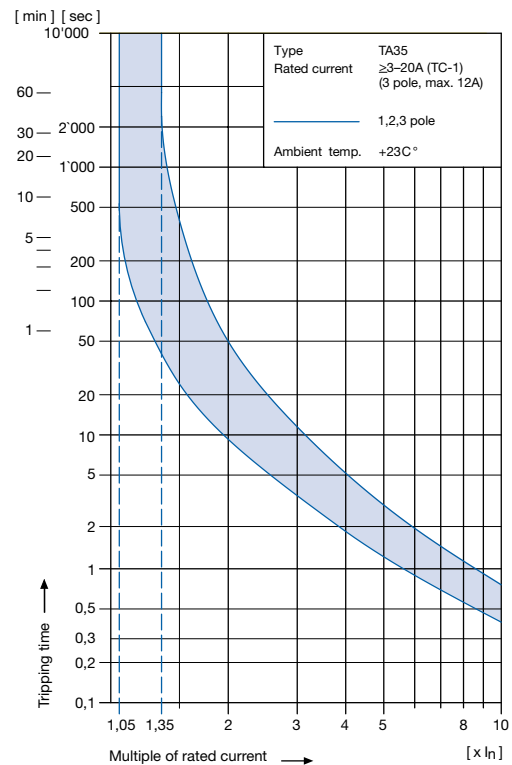
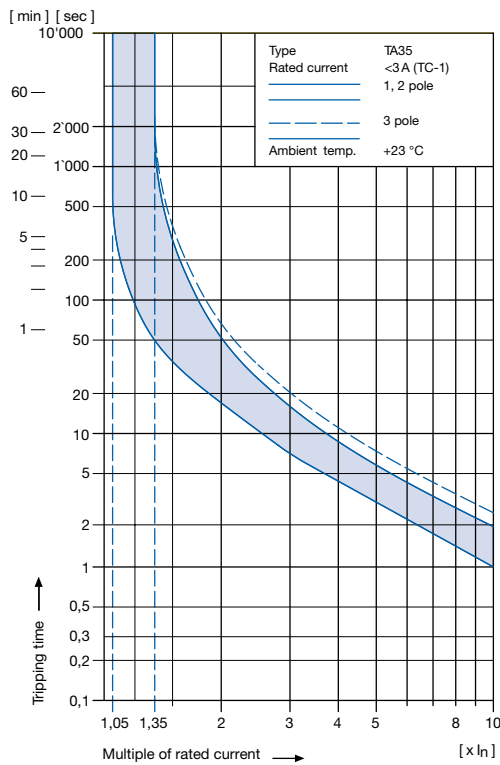

The above tripping characteristics apply to symmetrical overloads on all poles on the TA35 only.

At asymmetric overloads on multi-pole types, the tripping characteristic will change.

- If a 2-pole type TA35 is loaded at one pole only, the tripping current will be shifted by factor **1.05** (TC-2).
- If a 3-pole type TA35 is loaded at one pole only, the tripping current will be shifted by factor **1.10** (TC-2).

To meet the above tripping characteristic at asymmetric overloads on multi-pole types, the value of the rated current of the CBE has to be multiplied by the factor mentioned above.

Effect of ambient temperature

The unit is calibrated for an ambient temperature of +23 °C. To determine the rated current for lower or higher ambient temperature, use a correction factor from the table below.

Ambient temperature [°C]	Correction factor		
	1-pole	2-pole	3-pole
-30	0.77	0.76	0.76
-20	0.81	0.81	0.81
0	0.90	0.90	0.90
+23	1.00	1.00	1.00
+40	1.03	1.03	1.06
+50	1.04	1.04	1.10
+60	1.06	1.06	1.14

Example for 2-pole type:



Rated current at +23 °C: 5.0 A
 Ambient temperature: +50 °C
 Correction factor: 1.04
 Chosen rated current at +40 °C ambient temperature: **5 A x 1.04 = 5.2 A**

Standard rated currents and typical internal resistance

Code	I_n [A]	R_i [Ω]
Z05	0.05	200.0
J01	0.1	70.0
J05	0.5	2.750
J10	1.0	0.720
J15	1.5	0.340
J20	2.0	0.187
J25	2.5	0.115
J28	2.8	0.089
030	3.0	0.059
040	4.0	0.059
050	5.0	0.044
060	6.0	0.028
070	7.0	0.0142
080	8.0	0.0142
100	10.0	0.0109
120	12.0	0.0086
140	14.0	0.0072
150	15.0	0.0056
160	16.0	0.0056
180	18.0	0.0052
200	20.0	0.0052

unprotected poles (without bimetal) 2.2 m Ω

Approvals

			# of poles	Rated currents	Rated voltage AC	Rated voltage DC
	UL	UL 1077	1	0.05...20 A	240 V	32 V
			2	0.05...20 A	240 V	60 V
			3	0.05...12 A	415 Y/240 V	—
	UL	CSA C22.2 235	1	0.05...20 A	240 V	32 V
			2	0.05...20 A	240 V	60 V
			3	0.05...12 A	415 Y/240 V	—
	VDE	IEC 60934	1	0.05...20 A	240 V	32 V
			2	0.05...20 A	240 V	60 V
			3	0.05...12 A	415 Y/240 V	—
	CQC	GB 17701	1	0.05...20 A	240 V	32 V
			2	0.05...20 A	240 V	60 V
			3	0.05...12 A	415 Y/240 V	—

Actual information about approvals can be found on: www.schurter.com/approvals.

Order Code

Number of switched poles Number of protected poles	1-pole		2-pole			3-pole	
	0	1	0	1	2	0	3
Basic type	EFC	EFT	EBC	EBT	EBD	EKC	EKD

Other versions on request

TA35- **EBT** **T** **F** **120** **C0**

No other features

Frontbezel and actuation knob

	Bezel	Knob
T	black	black
N	without bezel	without knob

Bezel marking

	Surface	Symbol
F	relief recessed	I 0
N	no marking	no marking

Without thermal overload protection: code C00

With thermal overload protection: rated current I_n (A)

I_n	Code	I_n	Code	I_n	Code	I_n	Code
0.05	Z05	1.0	J10	4.0	040	14.0	140 *
0.1	J01	1.2	J12	5.0	050	15.0	150 *
0.2	J02	1.5	J15	6.0	060	16.0	160 *
0.3	J03	2.0	J20	7.0	070	18.0	180 *
0.4	J04	2.5	J25	8.0	080	20.0	200 *
0.5	J05	3.0	030	10.0	100		
0.8	J08	3.5	035	12.0	120		

Other rated currents on request.

* 3-pole max. 12A

Dimensions

TA35 1-pole

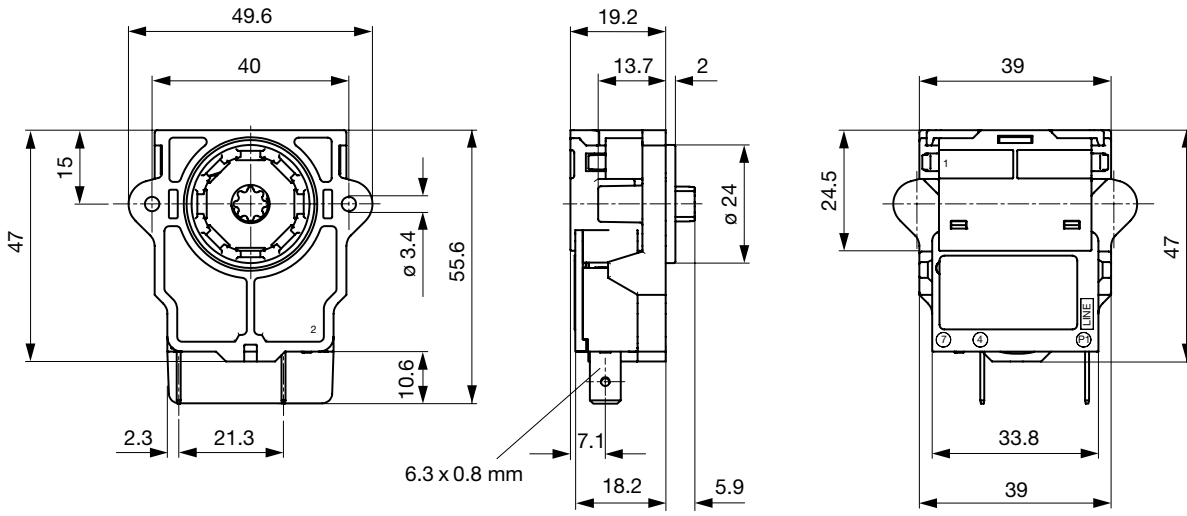

Screw Type: 2 x PT WN1413 KA 35 x 12

TA35 2-pole

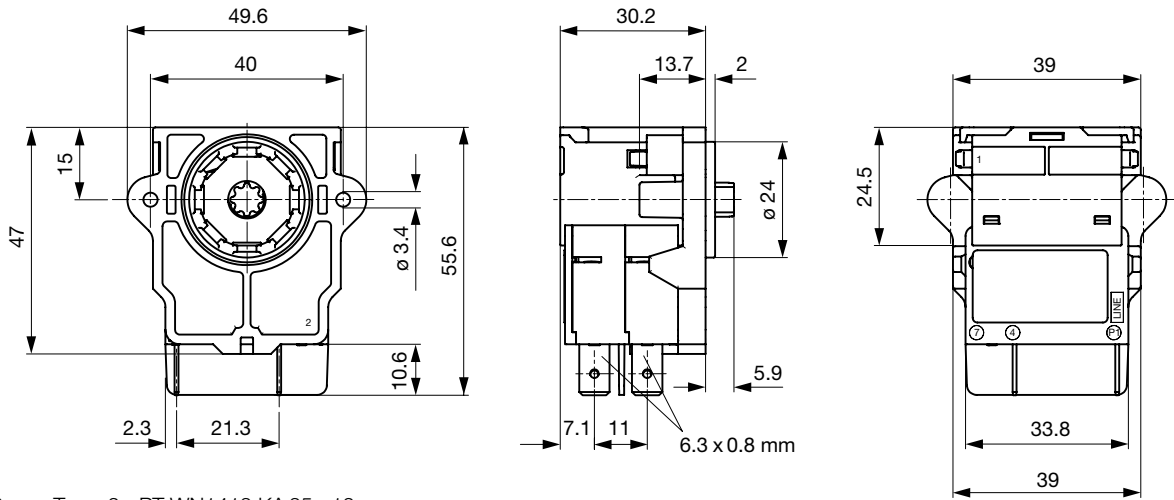

Screw Type: 2 x PT WN1413 KA 35 x 12

TA35 3-pole

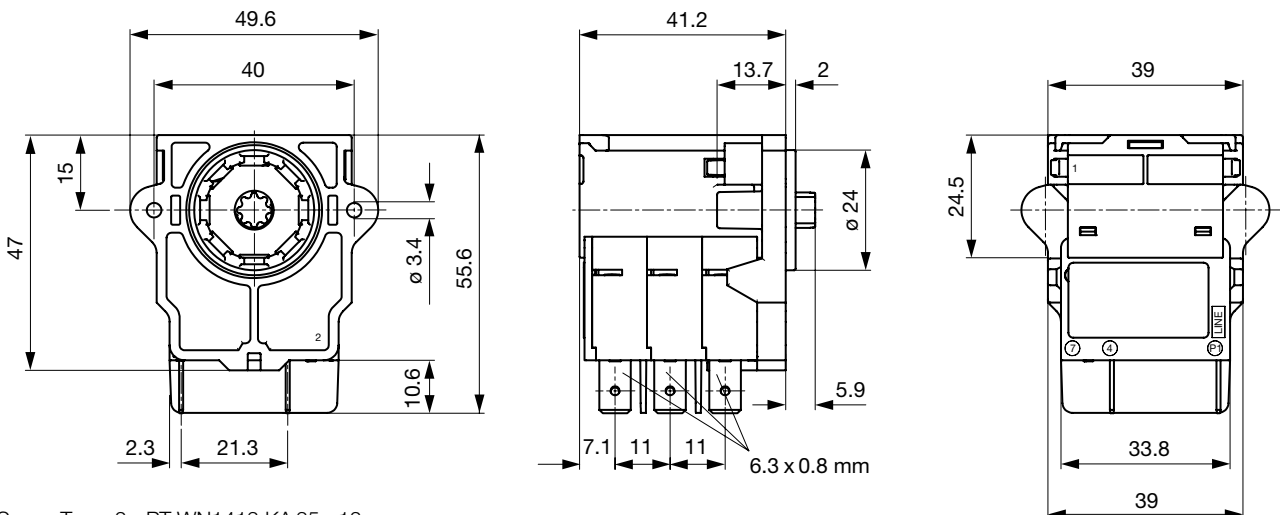

Screw Type: 2 x PT WN1413 KA 35 x 12

Front bezel/knob

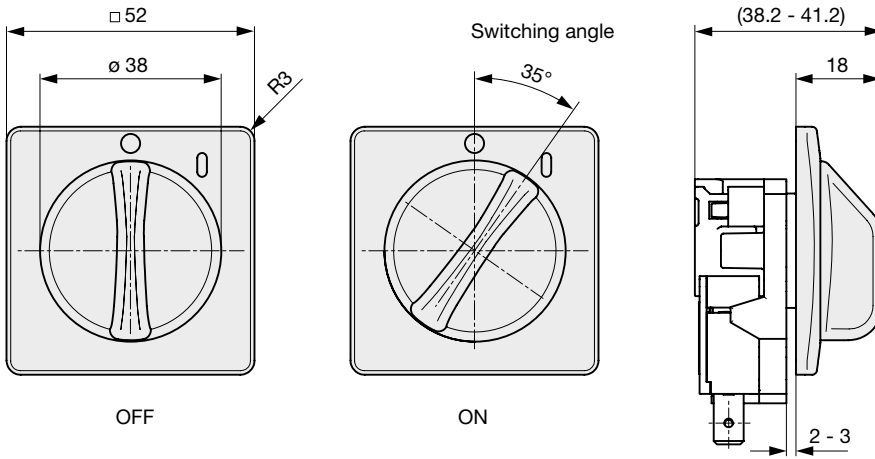

Cut-out

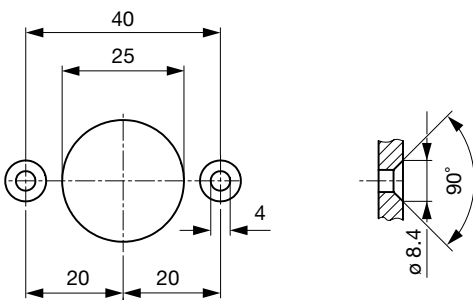

Mounting instructions



Customer specific bezels/actuator designs possible